

LOCKYER ELECTRONICS

Selcal Interface

Installation and Programming Manual



Lockyer Electronics

Installation and Programming Manual

Copyright

All information contained in this manual is the property of Lockyer Electronics. All rights reserved. This document or any parts thereof may not be reproduced in any form, on any media, or for any purpose, without prior written approval by Lockyer Electronics.

Disclaimer

There are no warranties extended or granted by this manual. Lockyer Electronics accepts no responsibility for damage arising from use of the information contained in the manual or of the equipment and software it describes. It is the responsibility of the user to ensure that use of such information, equipment and software complies with the laws, rules and regulations of the applicable jurisdictions.

Updates of Manual and Equipment

Lockyer Electronics reserves the right to make changes to any product herein to improve reliability, function or design. All specifications are subject to change without notice.

Some graphical images may differ from actual because of model variations.

Terms of Trade

All goods supplied by Lockyer Electronics are subject to our Terms of Trade a copy of which is available for download from our website www.lockyerelectronics.co.nz/download/TOTLong-17236v3.pdf.

Enquires and Comments

If you have any questions, comments, suggestions or notifications of errors please feel free to call, write, email or fax us at

PO Box 821 • Napier, New Zealand

Phone (06) 843-5716 • Fax (06) 843-5416

Email: rob@lockyerelectronics.co.nz

Website: www.lockyerelectronics.co.nz

Revision History

Date	Version	History
July 2008	1.3	
October 2008	1.4	Changes to Tait Radio settings

Selcall Interface

Description

The Selcall interface has been designed to provide serial commands from the TOCP to a Tait TM8200 mobile radio using the Tait proprietary command protocol, CCDI (Computer Controlled Data Interface). It connects to PL1 and PL12 on the TOCP Controller board and the 15 way D auxiliary connector on the Tait TM8200 mobile radio.

This interface provides a Selcall based turnout and status reporting system currently employed in the majority of New Zealand Fire Stations on their LMR network.

Programming is by using Hyper Terminal with provision at some later time to use Windows TOCP.EXE.

Selcal Format

Selcall strings are CCIR tone set with a tone period of 20ms, 5 address tones + status or command tone. The last or 6th address when decoded at a fire station from Firecomm is a command, and when encoded at a station is a status.

Format "legacy system", 5 tones (1 tone period each) + 2 silence periods + 2 periods of status or command tone.

Command code is the 6th code, (Decoded FROM Firecomm) this commands one or more outputs to activate. All commands are acknowledged with a status 0.

Command	Description	Output
0	Poll station	None
1	Bells and door #1	1 and 2
2	Bells and door #2	1 and 3
3	Bells and door #3	1 and 4
4	Bells and door #3	1 and 4
5	Bells and door #2	1 and 3
6	Bells and door #2	1 and 3
7	Bells and door #2	1 and 3
8	Bells and door #3	1 and 4
9	Reserved output	5

Not all Stations use outputs 2, 3, 4 and 5.

Status Code is the 6th code; (Encoded TO Firecomm) this status signals the action that has occurred at the station.

Status	Action	Input
0	Station Normal	None
1	Security Alarm	1
2	Reserved	2
3	Key Cabinet Alarm	3
4	Reserved	4
5	Fire Alarm	5
6	Mains Fail Alarm	6
7	Low Battery Alarm	7
8	Pager received Acknowledge	8

Typical Station decodes:

Command to station	Action	Acknowledge from station
186590	Station Poll	186590
186591	Turnout bells & Door 1	186590
186592	Turnout bells & Door 2	186590

Station Encodes

When a station Input is activated a status will be sent to Firecomm three times at an interval determined from the station ID code and varies from 5 to 9.5 seconds. These retries can be stopped by sending an acknowledge code to the station within Acknowledge Window" period of the call being initiated. This acknowledge code must be the same as the one received except with a "15" pre-code; e.g.

Received Code	Acknowledge Code
186591	156591
186504	156504
191727	151727

If the acknowledge to the station is sent outside the 5 to 9.5 second acknowledge window the station will not decode the call as an acknowledge and will resend the input status.

Installation

The Selcall Interface board can be mounded under the 12v Audio Amplifier board. A pin 1 to pin 1, pin 2 to pin 2 etc MTA100, 7 and 9 way plug lead assembly provides power supply and control connections between the TOCP and the Selcall interface board. A radio interface lead is also provided, this connects between the 15 way D auxiliary connector on the Tait TM8200 mobile radio and the Selcall Interface board, PL4.

Programming

HyperTerminal is an appropriate terminal program, freely available with Windows operating systems. See Appendix 3, How to set up and use Windows 'HyperTerminal'. A serial interface, provided by Lockyer Electronics, is required to program the Selcall Interface. Connect the 4 pin Test connector PL5 to the serial interface. Connect the DB-9 Connector on the serial interface to a PC running HyperTerminal.

Note that the serial interface, PL5 and the radio interface, PL4 cannot be connected to the Selcall Interface board at the same time. When programming the interface remove the radio interface plug connected to PL4. After programming remove the serial interface lead to PL5 before re fitting the radio interface lead to PL4. This is important.

All operating parameters that are configurable are stored in non-volatile memory. These parameters can be accessed and modified by interfacing to an IBM compatible PC via an RS-232 serial connection using any serial communications program configured as follows.

- 9600 Bits per second
- 8 Data Bits
- No Parity
- 1 Stop Bit.

After establishing communications with the controller, type the symbol ? then press **Enter** and a menu will be displayed showing programmable parameters.

Selcall interface programming example:

Selcall Interface

For example to view the station code type p1 then enter and the current station code will be displayed. To change the station code to 659 type p1 659 then press enter.

Menu Commands

Command	Description	Unit	Low Limit	High Limit	Default
b1	Acknowledge Window	Tenths Seconds	1	255	40
b2	Output Active Time	Tenths Seconds	1	255	15
b3	Ready wait Time	Tenths Seconds	1	255	20
b4	Retry Count		0	255	2
b5	Busy Tail	Tenths Seconds	1	255	5
b6	Pole Response Time	Tenths Seconds	1	255	35
b7	Pole Wait Time	Tenths Seconds	1	255	40
p1	Station Pre-Code		00	FF	18
p2	Acknowledge Code		00	FF	15
p3	Station Code		000	FFF	799
on	Outputs for Command n		1	F	
r	Reset Code				
n	Serial number				
u	Power up Message				
v	Version Message				
?	Help				
s	Displays status inputs	Status 1 to 8 (Left to Right)	0	1	11111111

Acknowledge Window See Station Encodes, page 2.

Outputs Active Time Defines the time that a station decodes activates its output for.

Ready Wait Time This sets the time that the interface waits for a response from the Tait TM8200 before trying again.

Retry Count This sets the number of times the interface resends a status call to Firecomm when no acknowledge has been received. If set to 0 it will only send the status call once.

Busy Tail This sets the time the interface waits before sending a Selcall sequence after the busy line from the Tait TM8200 becomes clear, i.e. not busy.

Pole Response Time When a Station is polled, any active input status will be sent in numeric order with status "0" sent first. The normal sequence is outlined below if inputs 1 and 5 are active when the station is polled;

	Action	Call from Firecomm	Call to Firecomm
1	Poll sent from Firecomm	186590	
2	Station reports normal condition		186590
3	Station reports input 1 active		186591
4	Firecomm acknowledges input 1 active	156591	
5	Station reports input 5 active		186595
6	Firecomm acknowledges input 1 active	156595	

The **Pole Response Time** is the time the interface waits between sending response from a pole; see line 2 above,(Station reports normal condition) and any active input status.

Selcall Interface

Pole Wait Time This sets the time between the pole response Selcall sequence (after status "0" sent first) and between any active input status sequence being sent as a result of a pole if no acknowledge sequence is received.

Station Pre-Code Station Pre-Code is the first two numbers in the code and are used to define the region the station is in;

Pre-code	Region
18	North Island
19	South Island
15	Firecomm Acknowledge

Acknowledge Code The Pre-code used to acknowledge a status call from a station.

Station Code Station code is the three digit station ID code. This with the pre-code makes up the five digit station code.

Outputs For Command n Any Command Received 1 through to F can be programmed to activate one or more of the 5 outputs. The "o" command is used to program which of the 5 outputs are activated when a command is received. A control bit format is used. When entering these values leading zeros can be omitted. For example to activate output 1 when command 1 is received enter "o1 1" or to activate output 1 and 3 when command 2 is received, enter "o2 101". Note the first letter entered is an o (o for output and not 0 as in zero) then the command required to be actioned on, then the last 5 bits are used to activate one or more of the five outputs.

Reset Code Required for Debugging only.

Serial Number Displays the unit's serial number.

Power up Message Displays the unit's power on count.

Version Message Displays software version information.

LED Indicators Two LEDs are provided to aid commissioning. The "Run" LED is seen occulting at a 1 second rate, if it remains on or off or flickers there is a processor fault. The "In Use" LED will light when the interface has successfully established communications with the Tait TM8200 mobile radio.

Tait TM series Radio Settings

These are the basic settings required to interface a Tait TM series radio to a Lockyer Electronics Selcall Module.

Serial Protocol:

Command Mode:

CCDI Enabled	
Baud Rate	9600
Flow Control	None
CCDI Port	AUX

Programmable I/O:

Digital:

AUX_GPI05	All	Output	None	Busy Status	High	None	None	None
-----------	-----	--------	------	-------------	------	------	------	------

Audio: (Only required if using PA)

RX	None	A-Bypass	Ir	On Ptt	R10	D-Split	Busy Detect
----	------	----------	----	--------	-----	---------	-------------

Conventional Data Parameters:

CCDI Mode:

Power up state	Command Mode
Output progress messages	Tick
Output All Selcall Receptions	Tick

Selcall:

Selcall Identity: / Detailed

"Add" button first then	
TX Format	RRRRR--S
RX Format	RRRRR—S
Tx Call Sub-Sequence Decoding	Tick
<u>Tone Setting:</u>	CCIR 20ms

Networks:

Basic Settings:

Signalling Type	Selcall
Signalling ID	1

Features:

Transmit Auto Ack Type	None
Receive Auto Ack	Unticked

REAR AUXILIARY CONNECTOR TM8250

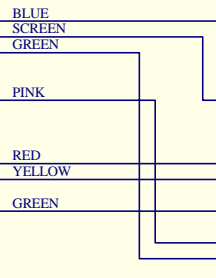
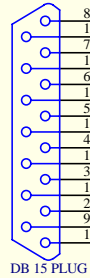

SECALL INTERFACE

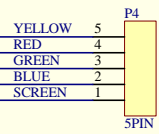

SERIAL DATA
SERIAL DATA
BUSY
RADIO/PROGRAM
GND

PA AUDIO

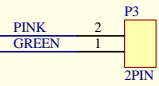

AUDIO
GND

Title			CONNECTION DETAILS TM8250 TO SELCALL INTERFACE		
Size	Number		Revision		
A4			TWO		
Date:	27-May-2009		Sheet 1 of	1	
File:	O:\PROJECTS\SELCALL\SELCAL-1.SCH		Drawn By:	ROB	

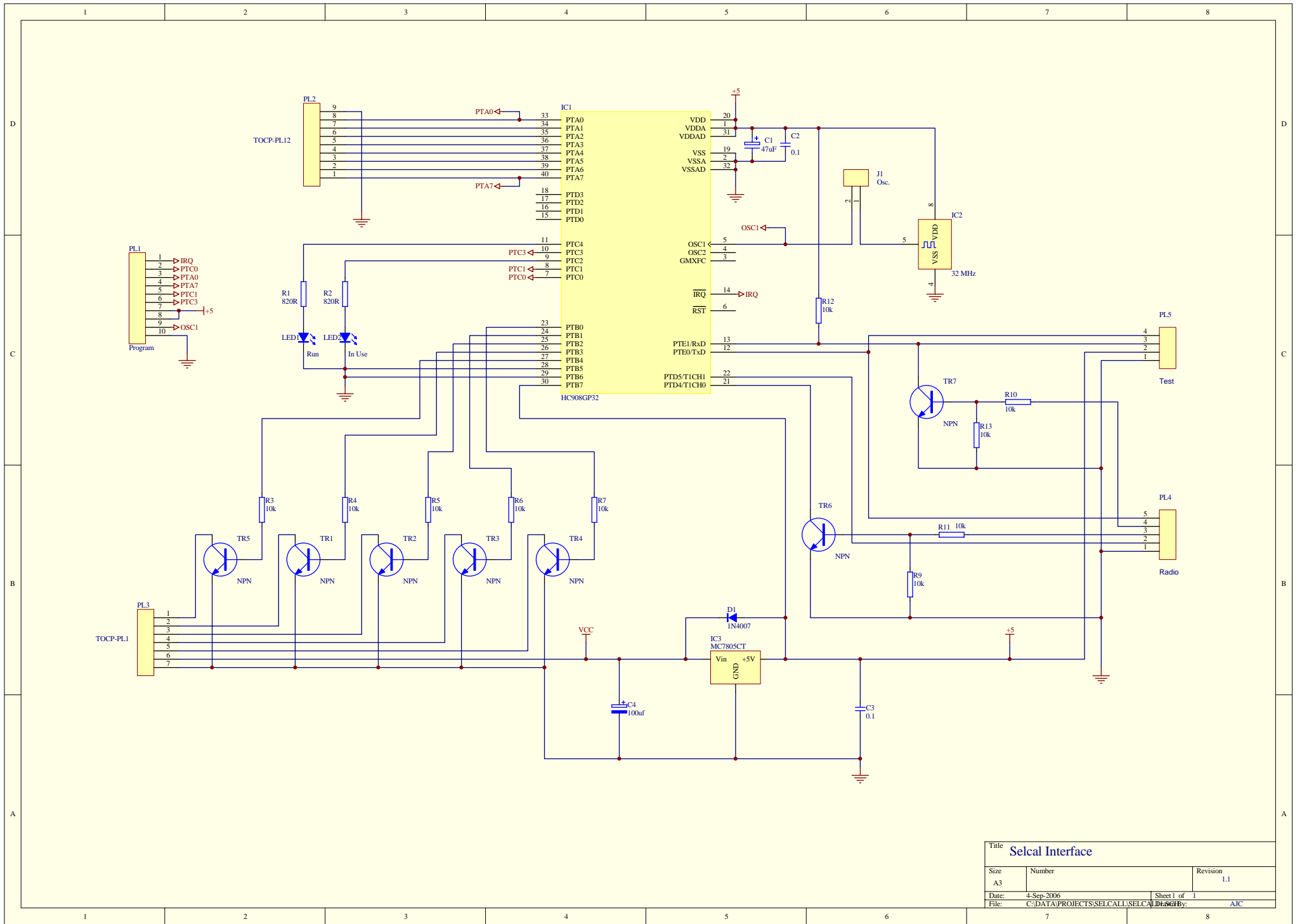

Title Selcal Interface		
Size A3	Number	Revision 1.1
Date: 4-Sep-2006	Sheet 1 of 1	
File: C:\DATA\PROJECTS\SELCALL\SELCAL.DWG	By: AIC	